



Donaldson
FILTRATION SOLUTIONS

Compressed Air Filtration

Ultramat®

UFM-D03 / UFM-D05 / UFM-D10

MAIN FEATURES & BENEFITS:

- Electronically, level-controlled condensate drain without pressure losses
- Permanent function control via LED display, automatic emergency programs in the alarm mode
- Easy maintenance, small inclination to emulsification, small noise during draining procedure, insensitive to dirt
- Service Unit - all maintenance parts in one unit, minimum expenditure with service and maintenance, early reminder for change of service unit (power/ service LED starts blinking)
- Aluminium corrosion-resistant, glass-fiber reinforced plastics, steadily against oil-contaminated and oil-free condensate
- Protection class IP 67 - very high protection against penetration of dust or water into the controller housing
- Multiple supply voltages, thereby world-wide use possible



Condensate drain without compressed air loss

INDUSTRIES:



- Chemical and pharmaceutical industry



- PCB assembly and CD manufacturing



- Surface finishing



- Machine building industry and plant engineering / construction



- Energy and power generation

Donaldson Filtration Deutschland GmbH
Büssingstr. 1
D-42781 Haan
Tel.: +49 (0) 2129 569 0
Fax: +49 (0) 2129 569 100
E-Mail: CAP-de@donaldson.com
Web: www.donaldson.com

Donaldson®
Ultrafilter

PRODUCT DESCRIPTION

The UFM-D's are compressed air zero-loss, electronically controlled condensate drains.

The large internal cross-sections for draining ensure reliable operation even when dealing with dirty, particle polluted condensate: Less downtime, less trouble and more safety for the application - especially in direct comparison with time- or float controlled drains.

Additionally the condensate becomes less emulsified – when compared with time controlled solenoid valves. Less emulsification and better function of oil/ water separators: longer compliance with legal discharge limits, less running costs!

As there is no air-loss whilst purging these drains work silent – a very important feature when this drain is installed within a working area!

The electronic control of the drain monitors the proper operation continuously.

Automatic malfunction routines and a potential free contact for remote control ensures safe operation at all times. You can react to malfunctions before they are obvious by condensate water in the compressed air line at the point of use!

Typical applications for the condensate drains UFM-D03 - UFM-D10 are:

Compressed air zero-loss draining of condensate at:

- compressors
- aftercoolers
- receiver-vessels
- pre- and after-filters of fridge dryers
- pre-filters of adsorption dryers
- condensate- and oil-removal filters
- pipe bends

Service Unit:

Complete replacement of all wearing-and pressurised parts with one swift moment.

- No electrical installation required during maintenance works
- No installation of seals or single components
- Only one replacement part, function-tested by the manufacturer
- Power / service LED starts blinking, if an change of the service unit is necessary (after 1 mio. operations or 2x 8760 hrs.)



PRODUCT SPECIFICATIONS

Features:	Benefits:
Electronically level-controlled	No expensive compressed air losses, condensate drain depending upon resulting condensate amount, sensor detects each kind of condensate (also pure oil), also in case of strong contamination the draining works problem-free
Electronic control	Permanent function control via LED display, automatic emergency programs in the alarm mode, potential-free alarm contact (not for UFM-D03), function test via test button, service LED starts blinking, if an change of the service unit is necessary
Generously dimensioned cross sections	Easy maintenance, small inclination to emulsification, small noise during draining procedure, insensitive to dirt
Multiple supply voltage: 95 - 240 VAC (50 - 60 Hz) / 100 - 125 VDC or 24 - 48 VAC (50 - 60 Hz) / 18 - 72 VDC	Universal use, world-wide
Protection class IP 67	Very high protection against penetration of dust or water into the controller housing
Service Unit	All maintenance parts in one unit, minimum expenditure with service and maintenance, warning if an change of the service unit is necessary
Materials corrosion resistant	Aluminum corrosion-resistant, glass-fiber reinforced plastics steadily against oil-contaminated and oil-free condensate (special equipments for particularly aggressive condensate available)
Condensate inlet vertically or horizontal, with UFM-D03 and UFM-D05 with swivelling angle adapter	Flexible and easy montage on different pipings possible

¹⁾ Max. performance for ambient temperature 20°C. 50% r. h.

PRODUCT SPECIFICATIONS

Technical Data	D03	D05	D10
min./max. operating pressure (see type plate)	0,8 - 16 bar (12-230 psi) or 1,2 - 16 bar (17-230 psi)		
min./max. temperature (see type plate)	+1°C - +60°C (+34°F - +140°F) or +1°C - +70°C (+34°F - +158°F)		
Condensate inlet	G ½ (½") innen, max. screw-in depth 13,5 mm (½")		3x G ½ (½") innen
Condensate outlet	G ¼ (¼") Ø 8 - 10 mm hose connector	G ¼ (¼") Ø 8 - 10 mm hose connector	G ½ (½") Ø 13 mm hose connector
Condensate	oil contaminated + oil free		
Weight (empty)	0,8 kg (1.8 lbs)	1,0 kg (2.2 lbs)	1,65 kg (3.63 lbs)
max. compressor performance ¹⁾	2,5 m³/min (87.5 scfm)	5 m³/min (175 scfm)	10 m³/min (350 scfm)
max. fridge dryer performance ¹⁾	5 m³/min (175 scfm)	10 m³/min (350 scfm)	20 m³/min (700 scfm)
max. filter performance ¹⁾	25 m³/min (875 scfm)	50 m³/min (1750 scfm)	100 m³/min (3500 scfm)
Supply voltage (see type plate)	95...240 VAC ± 10% (50-60 Hz) / 100...125 VDC ± 10% or 24...48 VAC ± 10% (50...60 Hz) / 18...72 VDC ± 10%		
Power consumption	P = 0,6...3,0 VA (W)		
Protection class	IP 67		
Overvoltage category (IEC 61010-1)	II		
Potential free contact (D05/ D10)			
Connection data switch to load	---	AC: max. 250 V / 1 A	DC: max. 30 V / 1 A
Connection data switch to low signal	---	min. 5 VDC / 10 mA	
Exclusion from the scope of application			
Not suitable for:	CO ₂ plants		

¹⁾ Max. performance for ambient temperature 20°C. 50% r. h.

DIMENSIONS

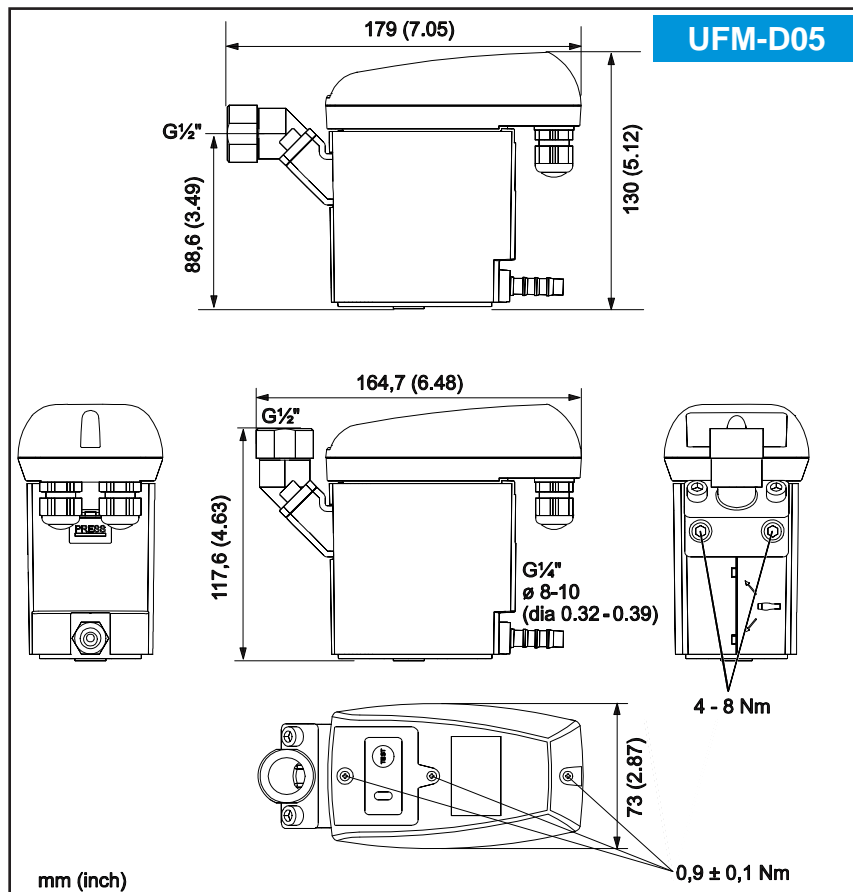
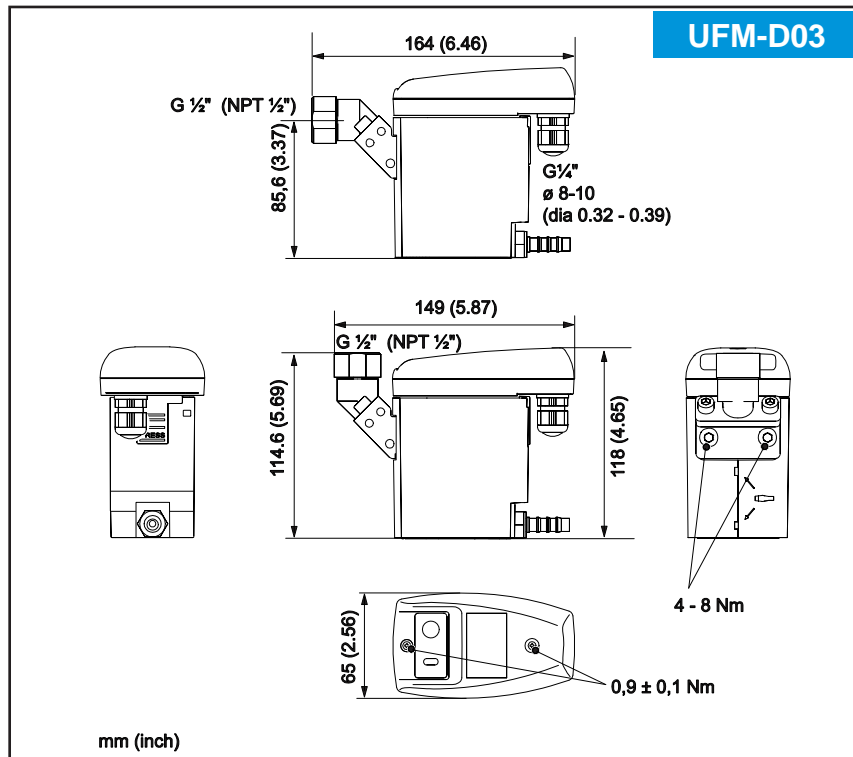

DIMENSIONS

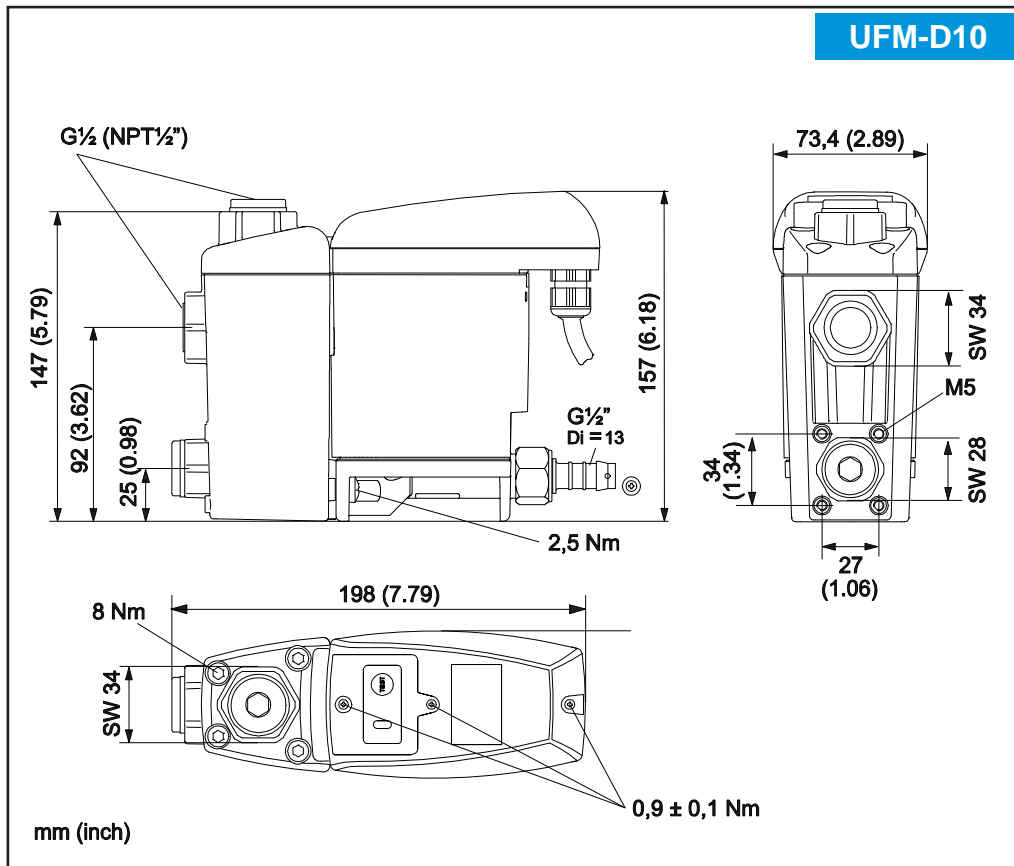

DIMENSIONS

Materials:	
Housing	Aluminium and fiber-glass reinforced plastic
Option:	
Bracket	